

HUSKY/NORSTAR PROFILE INSTALLATION GUIDE

Exposed Fastener

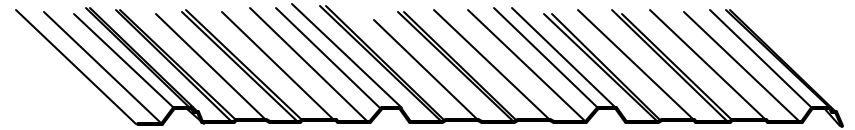

Husky

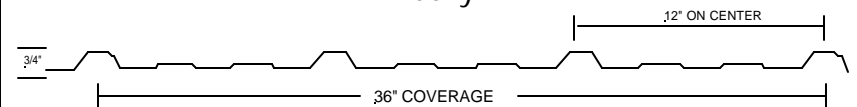

Nor Star

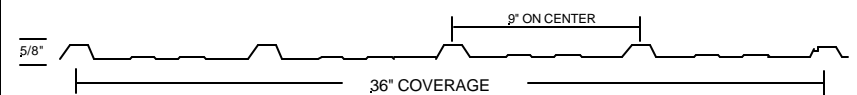

Available in these standard colors:

- White
- Dark Grey
- Light Grey
- Ocean Blue
- Zinalume
- Evergreen
- Forest Green
- Brick Red
- Light Stone
- Cocoa Brown
- Dark Brown



Magic Metals, Inc

5440 B Street
Anchorage, AK 99518

(907) 561-7663
(907) 561-7662 Fax
info@magicmetalsinc.com
www.magicmetalsinc.com

Frequently Asked Questions

Is skip sheeting acceptable or should I have solid sheeting?

If the structure is a cabin, then skip sheeting is ok. In a full time home, there should be OSB or CDX underlayment installed.

How do I figure the pitch for my roof?

Pitch is the amount (x) in inches that the roof rises every 12". It is then displayed as x/12.

What is the minimum pitch for a metal roof?

1/4 / 12 for standing seam
3/12 for EZSnap and exposed fastener

What spacing should I use for screwing down my roofing?

24" on center next to each high rib and 12" on center on laps and gables.

Should I run 1" x 4" over composition shingles, then install metal?

This is not recommended. The metal needs to be in contact with slip sheet (felt or ice & water shield) to prevent ice build up at dew point

Installing felt over shingles is recommended, then metal over felt.

What is so magic about Magic Metals?

Long story, but happy ending

Have additional questions or need a few more pointers?

Visit us on the web!

www.magicmetalsinc.com

Frequently Asked Questions

How long will it last?

Your metal roof will last the life of the structure

Can I do this myself?

Yes! 60% of our sales are installed by homeowners.

Is a metal roof noisy in the rain?

No, it is not. Insulation and sheeting absorb any sound.

What do I need under the metal?

For full sheeting, use O.S.B. or CDX, then put 2 runs of ice & water shield at the eave then run felt for balance of roof.

If skip sheeting is used (not recommended), run 30# felt the same direction as sheeting. Apply the felt as you lay the sheets. This will help so that at dew point, frost does not accumulate on the underside of the metal.

How much ice and water shield is needed?

Amount required by building code—3' inside heated wall line at eaves and 3' each side of valleys.

What kind of screw gun do I need to use?

Use a screw gun with a clutch. Adjust so fasteners do not spin out. Please see "Fastener Guidelines" for proper installation.

Why should I use sealer tape on my roof?

Very cheap insurance against capillary action—believe it or not water will run uphill.

What is the difference between plumb eave and 90 degree eave?



Trim Applications

Trim items are listed in the order that they are installed
Depending on roof configuration

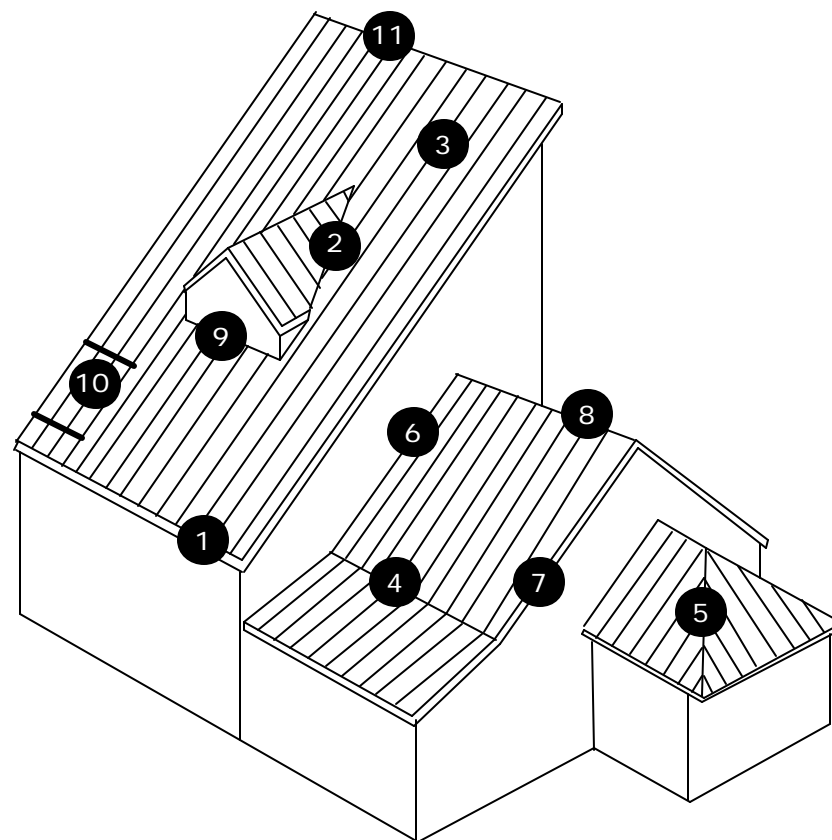

- | | | |
|---------------|-------------|----------------|
| 1. Eave | 5. Hip | 9. Endwall |
| 2. Valley | 6. Sidewall | 10. Snow stops |
| 3. Panels | 7. Gable | 11. Nose |
| 4. Transition | 8. Ridge | |

Eave Flashing

Eave flashing is applied along the lower edge of the roof to finish off the fascia board and seal the ends. Eave trim normally does not cover the full fascia board. A second piece of trim is available to complete the coverage (lower fascia wrap). The current code in Anchorage requires applying ice & water shield 3' up from the inside wall.

ITEMS NEEDED: roofing nails, tin snips, 1" woodgrips.

1. Place the eave flush with the fascia board. Tack on top 2' from each end with 8-penny nails.
2. Place the ice & water shield over the top edge of the eave trim. This seals the edge and prevents any seepage under the fascia board.
3. The eave trim should be lapped 2".
4. Fasten 1/2" from drip edge 2' on center.
5. Roofing panels should extend 1" past the edge of the eave.

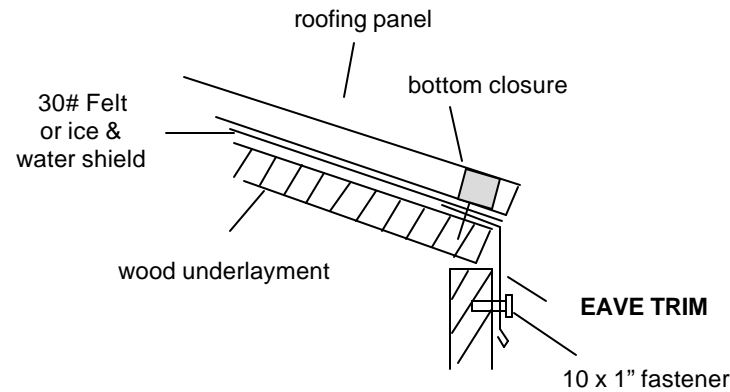

Specifications

Roof Specifications

- Husky Panel is an exposed fastener panel that covers 36".
- It is recommended that the Husky panel be applied on a roof with a minimum pitch of 3/12

Paint System

- Standard colors are available on 29 gauge steel, custom colors are available upon request.
- Akzo Nobel Coatings, Inc.
- An Advanced silicone modified polyester coating created from field proven combinations of proprietary resin technology and long lasting, color-fast ceramic pigments delivering a unique combination of quality and value in a high durability finish.

Warranty

25 year limited warranty available at time of purchase

Fastener Guidelines

Screws need to be properly driven to ensure proper seal and holding strength. Sealing material slightly visible at edge of metal washer. Assembly is weather tight.

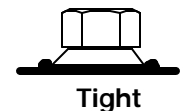
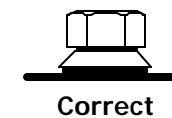
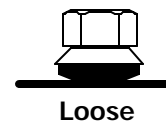

Skylight / Chimney Kit

Flashing Preparation

- Trim and bend the right side flashing as indicated. Trim the left side in a similar fashion. (keep in mind the uphill from the downhill ends).

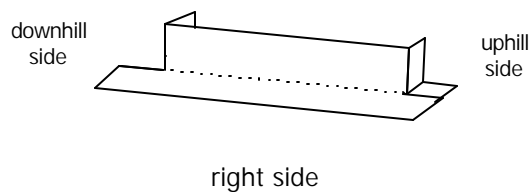

- Trim both ends of the uphill and downhill sides of the flashing.
- Slide the uphill flashing into the slots of the roofing and apply a liberal amount of gunable caulking.
- Assemble the skylight/chimney kit.

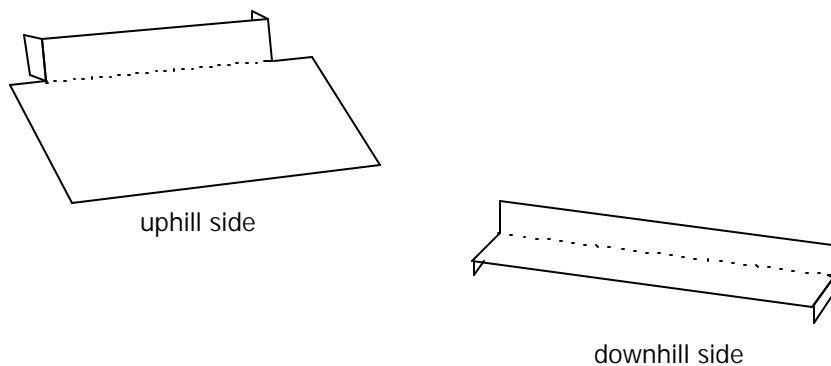

Valley Flashing

Valley flashing is applied where two adjacent roof lines join to create a means for water and snow evacuation.

ITEMS NEEDED: ice & water shield, butyl tape, bottom closures, 1" woodgrips, truss head screws, tin snips, straight edge, pencil.

- Valley is to be applied before roofing panel.
- Cover valley area with ice & water shield 30" up both sides, lapping 6" at the base.
- Place valley in joint roof lines. Screw in place at top edge. Lap valley flashing 12" with a row of butyl tape between.
- Seal the top edge with a 12" strip of ice & water shield the full length of the valley on both sides.
- Place a 2x6 board in valley as a guide for marking the beginning of the roofing panels. Mark line and remove board.
- Place two rows of butyl tape along line.
- Cut roofing panel to match angle and pitch of valley flashing.

Cut bottom closures to fit cut edge of panel and secure with 1" woodgrips along line.

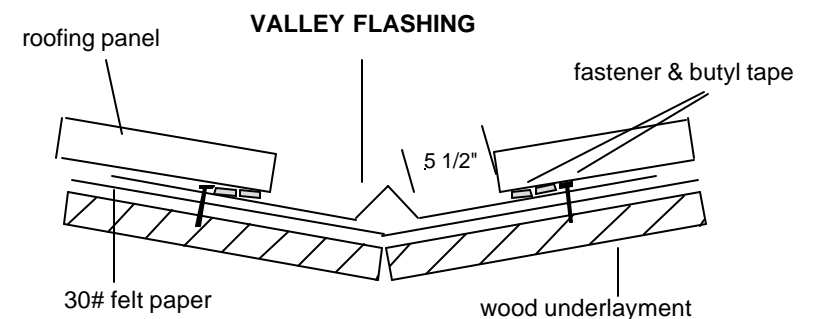

Roofing Panel

TOOLS NEEDED: Tin snips, screw gun (cordless preferred), drill with 1/8" drill bit

1. Pre-drilling of wood grip fasteners will greatly reduce panel application time and improve appearance.
2. Stack panels in piles of 10. Panels of one length that are to be laid out in the same direction or placed on the same side of the building must be piled together. All panels in pile must be flush at eave end for roof sheets or base end for wall sheets.
3. **Stitch Screw Spacing**—Drill holes (overlap panel only) for panel fasteners with 1/8" drill bit. Stitch screws are to be drilled on the roof. They are used to bind (stitch) the panels together, not to fasten to underlayment. Spacing for stitch screws are 12" apart starting 3" from eave.
4. **1" Screw Spacing**—Fastening of roof panels to plywood is accomplished by screwing 1" woodgrips with neoprene washers through the 1/8" drill hole. DO NOT over tighten. Spacing for woodgrip screws are 24" apart (next to each high rib) starting 3" from eave.
5. Sealer tape is recommended between all roof side laps and end laps, especially with a pitch of 4/12 or less.
6. Stitching screws are applied to the overlap rib. The screw must be allowed to drill its own hole through the under lap rib.
7. Sweep or wipe off drill tailings from panels.
8. The finished panels should look something like this:

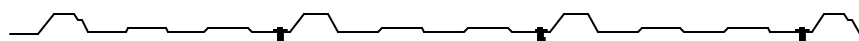

Stitch Screw & Sealer Tape Placement

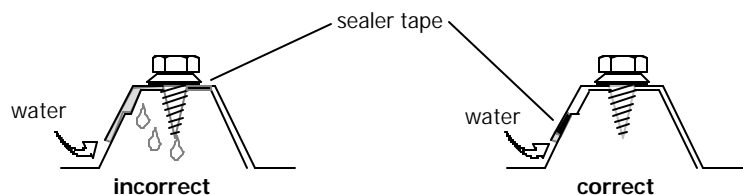

Skylight / Chimney Kit

- Whenever possible position the skylight/chimney curb so the ribs of the roof panels do not interfere with the flashing
- Cut the skyline roof panels as close to the left, right and downhill sides of the curb as possible. Cut the uphill side 6" from the curb.
- Do not fasten down the panels a minimum of 24" uphill from the skylight.
- The flashing will be 4" wider than the width of the curb (2" on each side). Cut a 1/8" slot in the two uphill corners of the roof panels slightly wider than 2" so the uphill flashing can slide through the two slots.

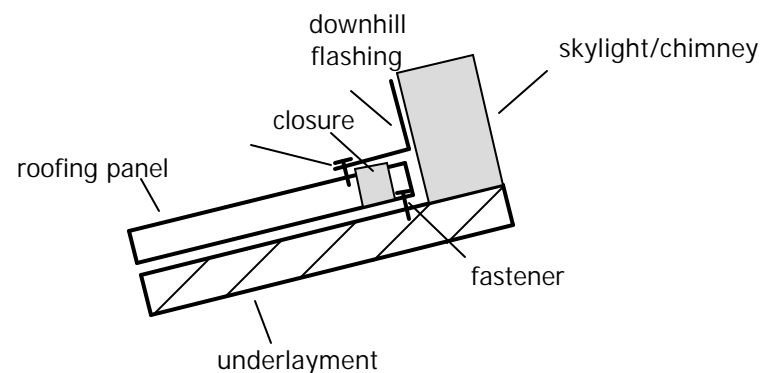
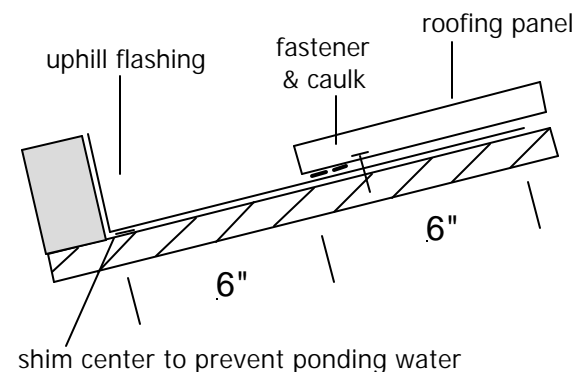

C Channel / Dektite

C channel is used to trim openings for windows, doors and vents. Application varies depending on application. The drawing shows general use.

ITEMS NEEDED: 3/4" stitch screws, pop rivets, tin snips.

Apply channel over the edge you are wanting to close off. Make sure the 3" side is flush with the panel being closed off. Depending on clearance, secure either with the 3/4" stitch screws or pop rivets.

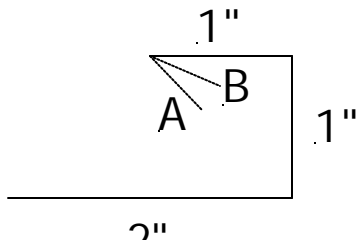

Dektite

1. Trim the opening on the dektite to 20% smaller than the pipe diameter.
2. Slide dektite down over pipe.
3. Seal between the dektite and the roofing with gunnable caulk and set the dektite.
4. Form the dektite to fit the profile of the roof.
5. Fasten the dektite with #10-1" woodgrips at 1" on center.

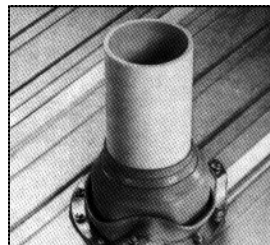

Transition Flashing

Transition flashing is applied between two differing roof slopes on the same roof line to seal the area between the pitch change.

ITEMS NEEDED: ice & water shield, top & bottom closures, 1" woodgrips.

1. Apply a continuous piece of ice & water shield 18 inches above and below flashing.
2. Metal roofing panels are applied to lower roof.
3. Transition flashing is installed with top and bottom closures.
4. Apply upper roof panels. Don't crowd flashing at bottom—hold up 1" from break. Install bottom closure with each panel.

Caution—do not install felt in this area. Only above and below.

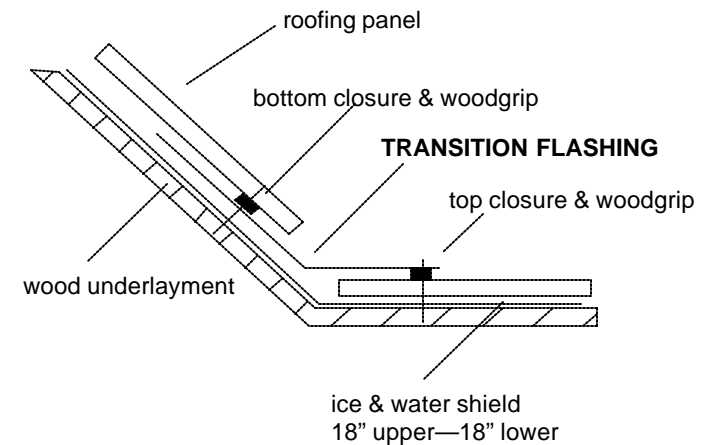

Gambrel Flashing

Gable flashing is applied to finish sloped ends (gable or rake) of your roof and is applied over roofing panels.

ITEMS NEEDED: 1" woodgrips, top & bottom closures, drywall screws, sealer tape.

4. Apply roofing panels to bottom half of roof. Make top square with edge of sheathing.
5. Apply top closures to lower roof adhering with sealer tape.
6. Apply gambrel flashing with drywall screws every 24".
7. Apply top half of roof line, extending lower edge 1 1/2" over sheathing.
8. Tuck bottom closures under panel and fasten panel, closure and flashing to sheathing.

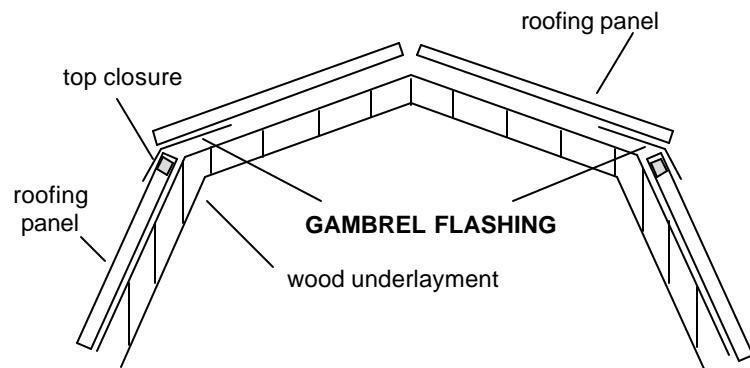

Prow Flashing

Prow flashing is applied along the sloped edge of the roof in place of gable trim. A prow is a sloped edge of a roof with the ridge extending out further than the eave.

ITEMS NEEDED: bottom closures, tin snips, 1" woodgrips, butyl tape, 8-penny nails.

1. Attach the prow flashing to the wood underlayment, making it flush along the fascia starting at the bottom.
2. Tack on top edge 2' from each end with roofing nails.
3. Place a 24" strip of ice & water shield along the edge of the prow flashing, lapping 2". Make sure you cover over nails.
4. Parallel to the edge of the flashing, place two rows of butyl tape 4 1/2" & 5 1/2" in from the face of the flashing.
5. Universal foam is placed 4 3/4" in parallel from the face of the flashing.
6. Field cut panels holding back 4 1/2" back from the face of the flashing.
7. Fasten panels to roof, ensuring that fastener passes through flashing and panel between two rows of butyl tape. Fasteners spacing is 4" on center

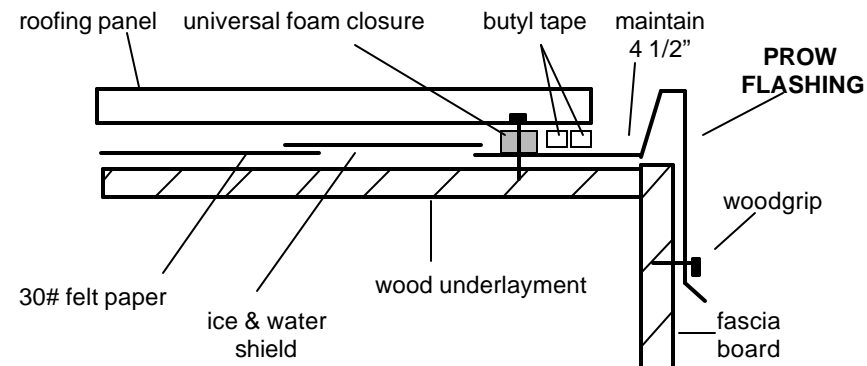

Nose Flashing

Nose/Apex flashing is applied to the peak of a single slope roof. It is custom made to match the slope/pitch of the roof.

ITEMS NEEDED: screwgun, tin snips, 1 1/2" and 1" screws, sealer tape.

1. Place nose/apex flashing over the peak starting at the leeward side, (needed if you have a prevailing wind). Place closure strips secured with sealer tape between the nose flashing and the panels to seal the space between them.
2. Fasten the nose flashing with 1 1/2" screws through the high rib of the panel into wood underlayment.
3. The fascia of the nose flashing should be secured across the edge every 24" just above the drip edge.
4. The end of the nose flashing can be finished in several ways:
 - A. It can be placed flush with the gable trim. Place sealer tape along the edge of the nose flashing to seal the end.
 - B. Several inches can be extended over the edge of the roof, then trimmed and folded to cover the end of the nose flashing like a cap. This method requires precision cutting.

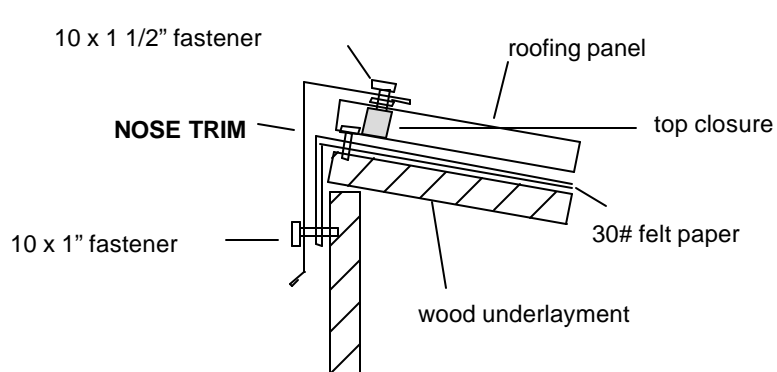

Hip Flashing

Hip flashing is applied along the sides of two adjacent roof lines. It covers the exposed sides to prevent leakage. There are two types of hip roofs. One comes to an apex, similar to a ridge. The other has a flat top and is called a Dutch hip.

ITEMS NEEDED: top closures, tin snips, sealer tape.

1. Trim roofing panels to fit roof and fasten in place.
2. Place a C channel along the edge of both roof lines with the long leg under the roofing panel.
3. Place a top closure with sealer tape adhered to the bottom inside the C channel. This will seal off the end of the panel.
4. Place the hip flashing on top of the roofing panels and fasten with 1" woodgrrips.

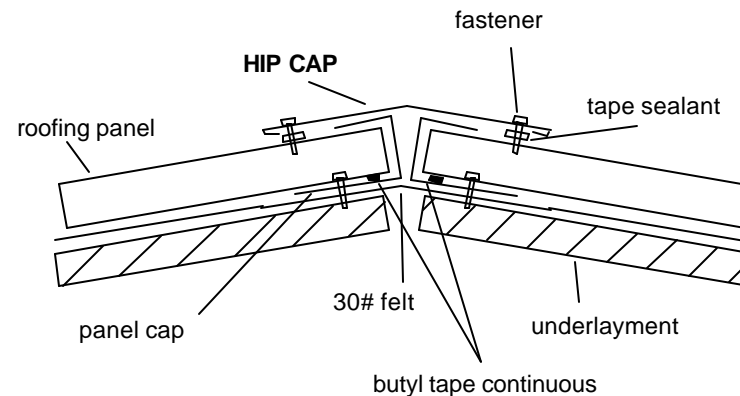

Sidewall Flashing

Sidewall flashing is applied to the panel side that runs along a wall. Its purpose is to prevent any leakage between roof and wall.

ITEMS NEEDED: screwgun, caulking, tin snips, 1" woodgrips, sealer tape.

1. Apply the sidewall flashing over the roofing panel starting at the eave and overlapping the flashing 6". Sealer tape should be applied to the bottom and top edge of the side wall flashing. The peel-off can be removed once the flashing is in place.
2. Fasten the flashing with 1" woodgrips to the flat portion of the roof panel every 12".
3. After the flashing is in place and fastened to the roof and wall, apply a 1x4 along the top for a finished look.

Seal the top edge of the 1x4 with caulking. Paint the 1x4 to match house.

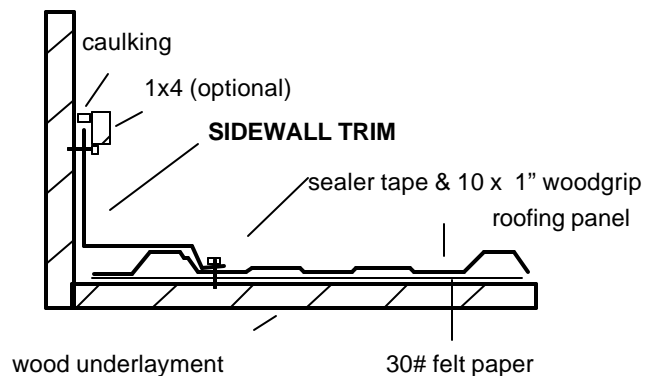

Snow Stops

Snow stops are applied to prevent shedding of snow from a specific area on your roof.

ITEMS NEEDED: butyl tape, screw gun, 1 1/2" woodgrips.

1. Determine the length & width of the area needing snow stops. Deduct 4' from the length (eave and ridge measurements), then divide the measurement by 3'. You will be placing the snow stops up the roof line every 3', perpendicular to eave, leaving 4' at the peak. Because the snow stops are 10' wide, the width of the area is divided by 9 to allow for overlap.
2. The snow stop is applied to the high rib of the roofing, allowing any melting snow or rain to run under the snow stop.
3. Place butyl tape on high rib under snow stop.
4. Fasten both sides of snow stop at each high rib with 1 1/2" woodgrips. The woodgrips will fasten through the metal into the wood underlayment.

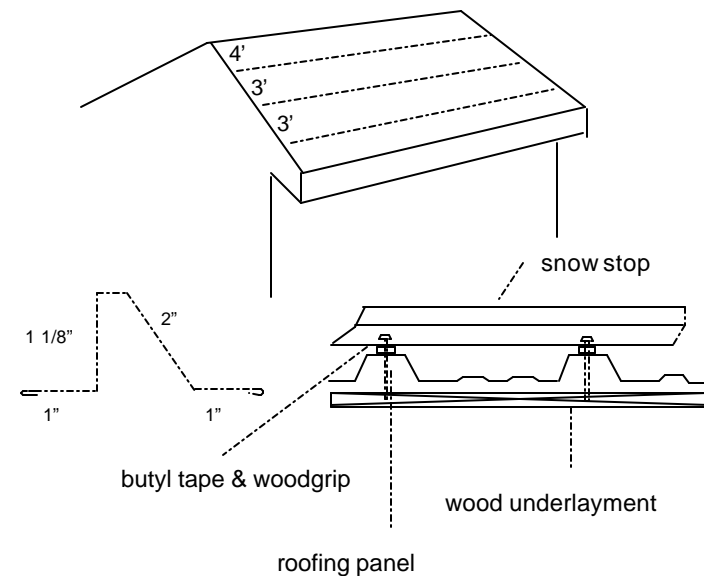

Endwall Flashing

Endwall flashing is applied along the end of the roofing panel to seal the area where the roof and a wall join.

ITEMS NEEDED: screwgun, 3/4" stitch screws, bottom closures, tin snips, sealer tape.

1. Place flashing flush with the wall over applied metal roofing.
2. Place bottom closure secured with a strip of sealer tape between the flashing edge and the roofing.
3. Place a row of sealer tape along the top edge of the flashing.
4. Screw the flashing, closure and panel together at the high rib of the roofing at every 12".
5. Screw flashing to the wall.
6. Install 1x4 across the top of the flashing to secure and give a finished look. Seal top edge with caulking. Paint 1x4 to match house.

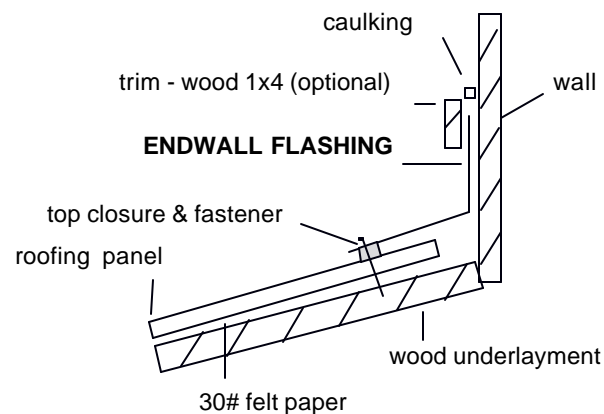

Gable Flashing

Gable flashing is applied to finish sloped ends (gable or rake) of your roof and is applied over roofing panels.

ITEMS NEEDED: Screwgun, sealer tape, 1" woodgrips.

1. After roofing panel is applied along the sloped edge of the roof, place a row of sealer tape along the lip of the gable. Because this product as a peel-off, it can be put in place and the peel-off removed in place on the roof.
2. Apply gable trim flush with the eave then overlap up the roof.
3. Overlap the flashing approximately 1-3 inches.
4. Fasten the top lip with 1" woodgrips every 12".
5. Fasten the lower end of the gable with 1" woodgrips every 24" starting 1/2" up from drip edge.

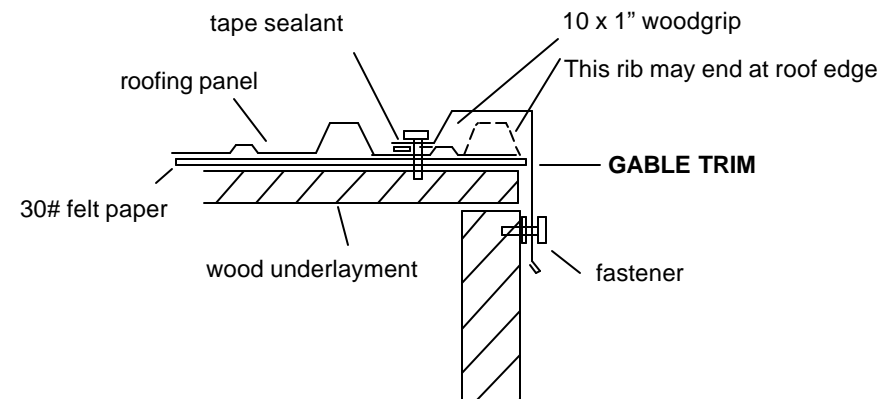

Ridge Flashing

Ridge flashing is applied to peak of gable roof. It is the last piece of flashing applied. Make sure you are secured by a safety line before installing.

ITEMS NEEDED: screwgun, top closures, tin snips, 3/4" stitch screws, sealer tape.

1. Place the ridge over the peak starting at the leeward side (necessary if you have a prevailing wind).
2. Place closure strips secured with sealer tape between the ridge and the panels to seal the space between them.
3. Fasten the ridge with 3/4" stitch screws through ridge edge, closure and high rib of the panel. Spacing is every 12".
4. The end of the ridge can be finished in several ways:
 - A. It can be placed flush with the gable trim. Place sealer tape along the edge to seal the end.
 - B. Several inches can be extended of the ridge like a cap. This method requires precision cutting.

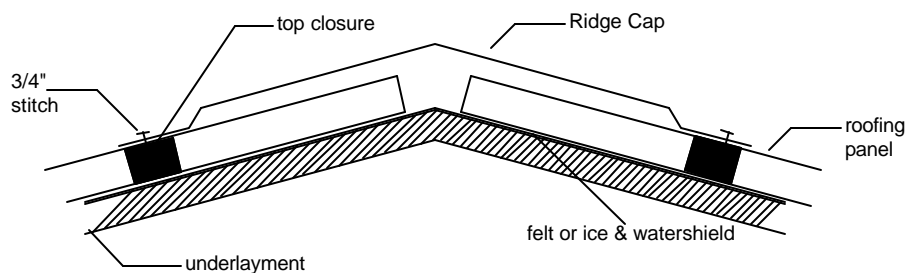

Vented Ridge Flashing

Vented ridge flashing allows air flow out the top of the roof for optimum air movement. Air movement (convection) is very important in maintaining a cold roof.

ITEMS NEEDED: 1 1/2" woodgrips, staples, tin snips.

1. The gable flashing must be installed prior to installation of the vented ridge flashing.
2. Wood underlayment should be held back 1 1/2" from each side for venting. Total space 3".
3. Install perforated liner. Proper installation places two inside perforated sections above ventilated area. Peel off strip and place universal foam between the perforated sections on each side.
4. Place liner with universal foam closure in place on roof and screw in place on each corner. No need to overlap liner. Butt up to each other.
5. Install ridge cap over liner fastening through ridge, liner and high rib of panel through to underlayment using 1 1/2" woodgrips.
6. Perforated liner is not functional on overhangs. Seal bottom with profiled closure.
7. Seal end of ridge by placing C channel in open area at ends. Screw in place.

